



T-20 LABEL REWINDER  
USER'S GUIDE

# CONTENTS

- 1      BOX CONTENTS**
- 2      GETTING TO KNOW YOUR T-20 REWINDER**
  - Device overview
- 3      REWINDER SETUP**
  - Connection
  - Loading the Label
  - Install the Stop Plate
  - Remove the Stop Plate
  - Label Core Sizes
  - Use of Label Core Adapters
  - Rewinding Modes
  - Motor Fixed Speed Mode
- 4      REWINDER STATUS**
  - LED indicator
  - When the rewinder is full
- 5      TROUBLESHOOTING**
  - Sensing error
  - Idle load

## DOCUMENT DESCRIPTION

T-20 Label Rewinder

Version       : **Rev. 1.02**

Issue Date   : **2013.11.30**

Part NO.     : **313-042200-203**

If you are looking for manuals in other languages or newer editions,  
please visit our website [www.godexintl.com](http://www.godexintl.com).

# 1 BOX CONTENTS

- T-20 Label Rewinder

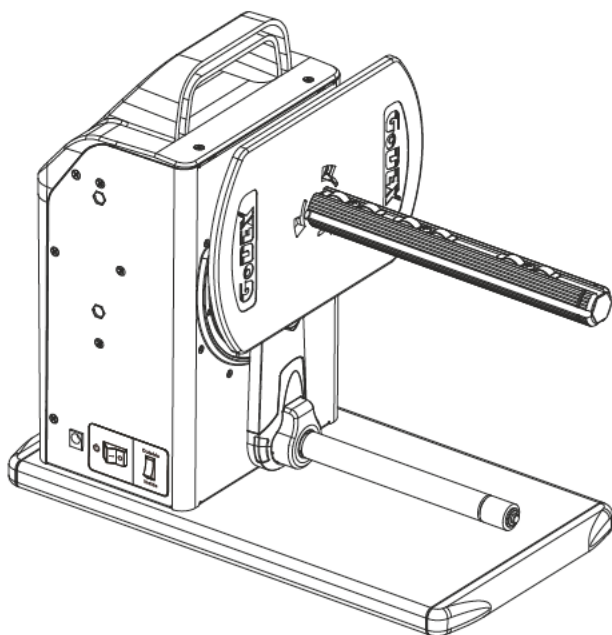

- Paper Stop Plate

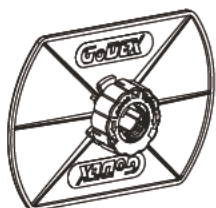

- Power Adapter



- User's Guide

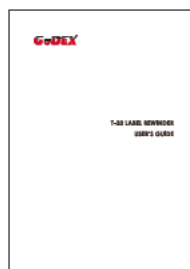

- Paper Clip

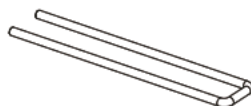

- 1.5'' Adapter



- 3'' Adapter

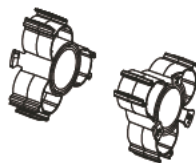

## 2 GETTING TO KNOW YOUR T-20 REWINDER

### Device Overview

#### Front View

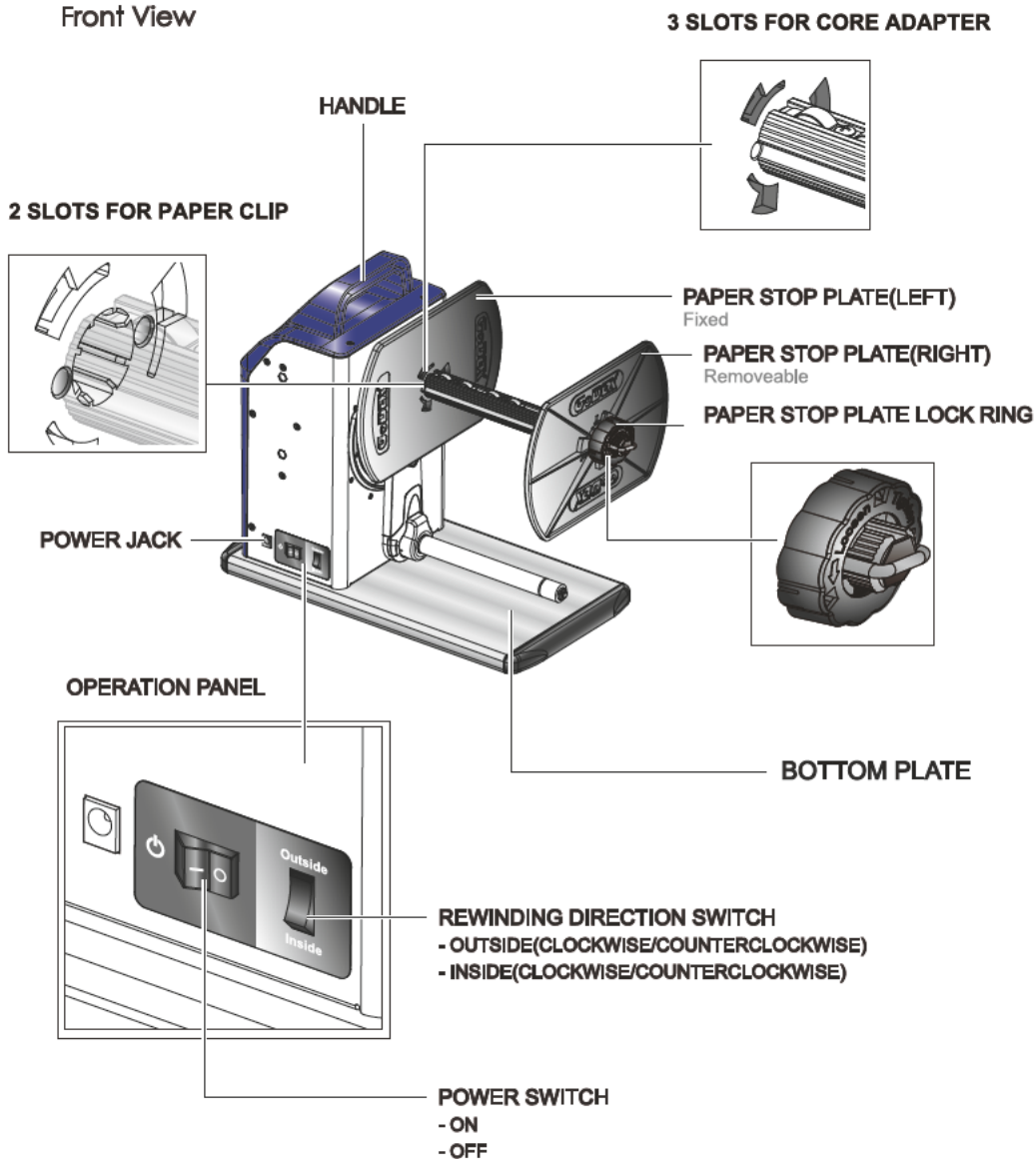

- **Rear View**

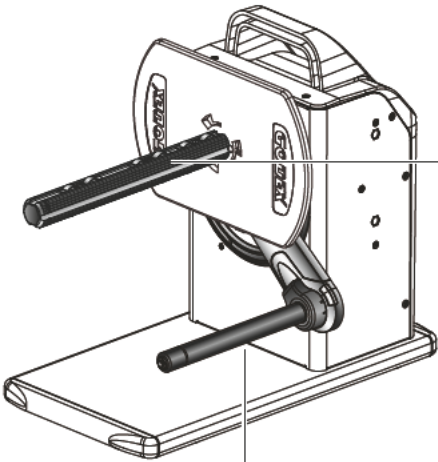

**LABEL REWINDING SHAFT**

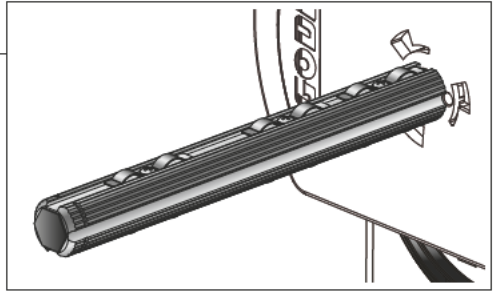

**CONTROL MECHANISM**

- Start
- Direction
- Status

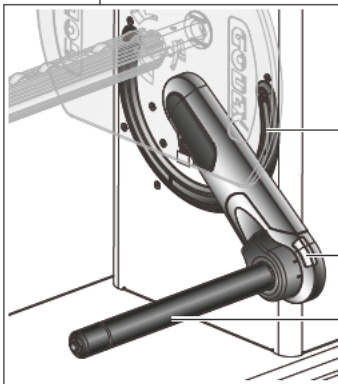

**GUIDE TRACK**

**LED INDICATOR**

**IDLER ARM**



**Keep Clean**

# 3 REWINDER SETUP

## Connection

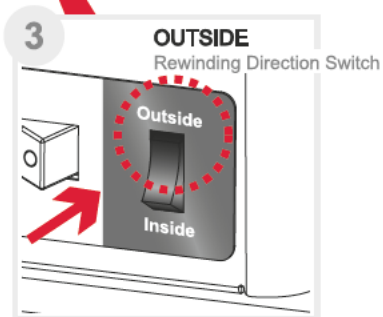
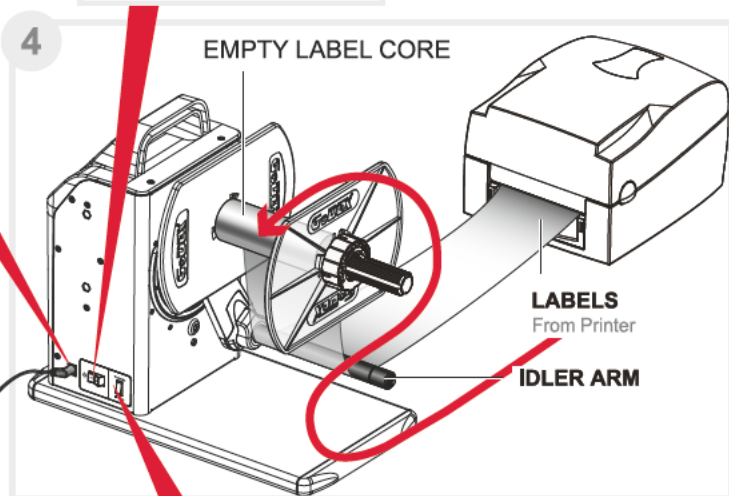
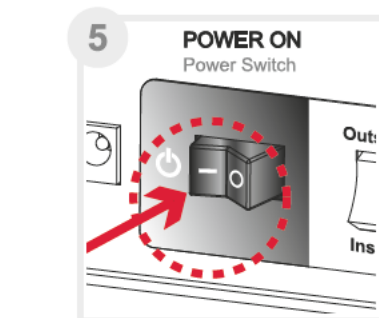
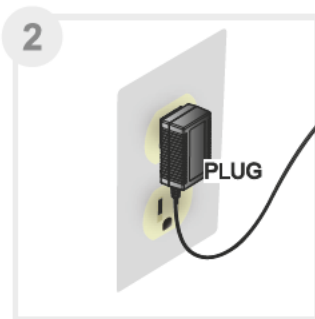
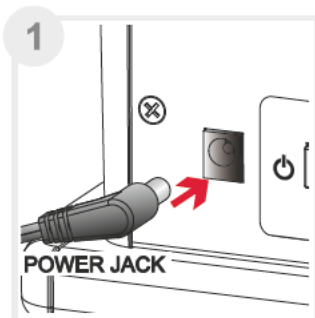

## Loading the Label

### Label Stock

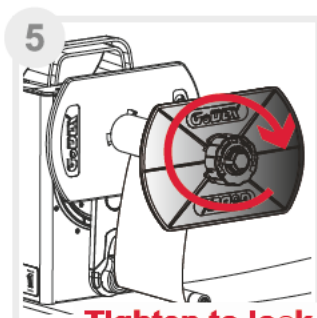
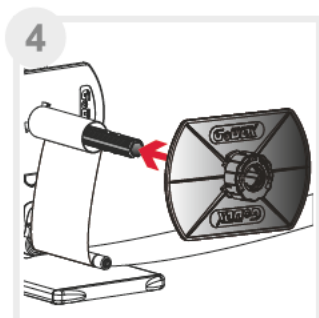
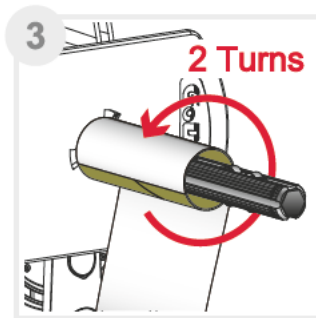
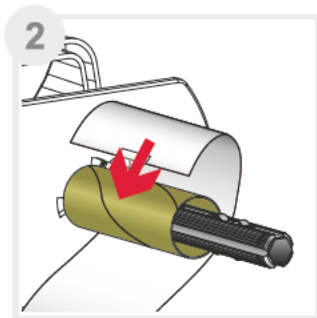
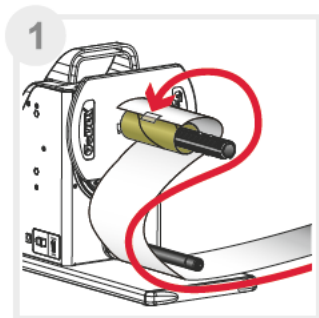
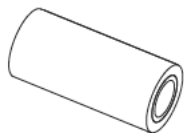

**Tighten to lock**

## Install and Remove the Stop Plate

### Install

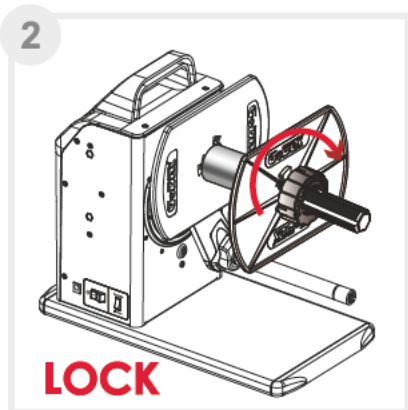
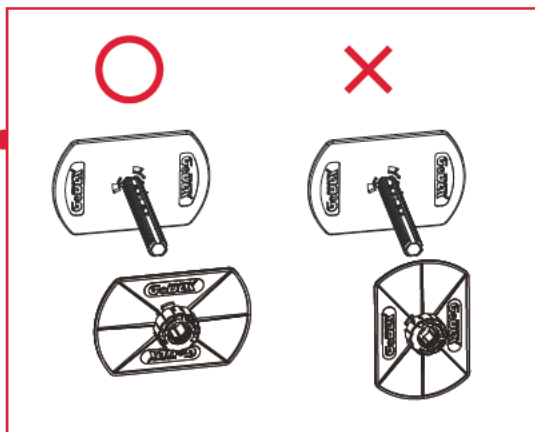
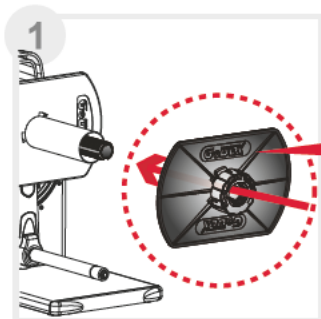

### Remove

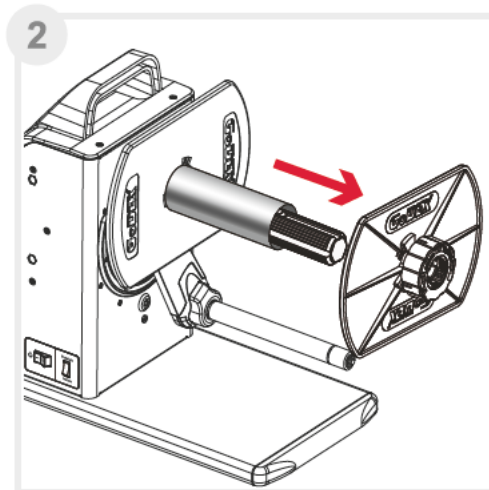
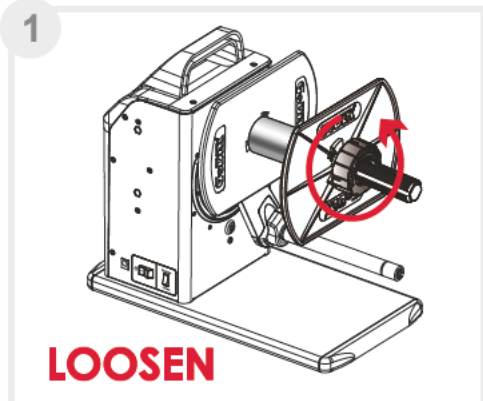



## Label Core Sizes

### Paper Clip

For use with 1" cores to secure labels

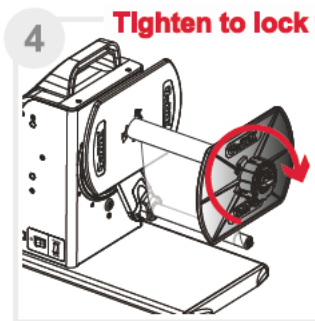
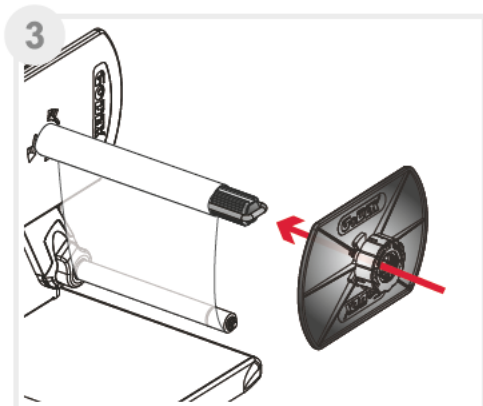
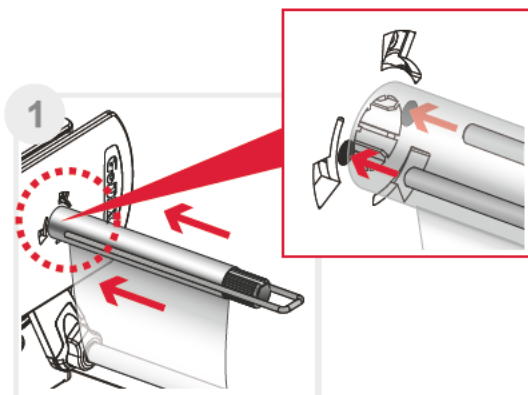

# Core Adapter for 1.5" and 3" Label Cores

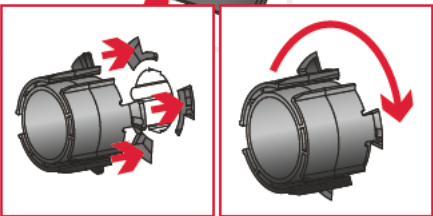
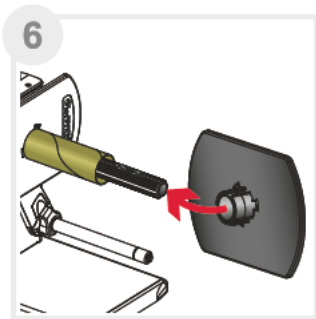
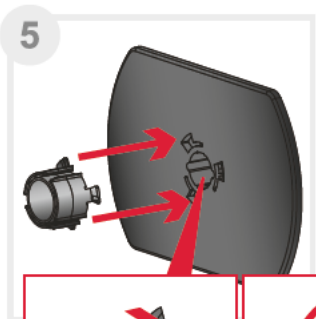
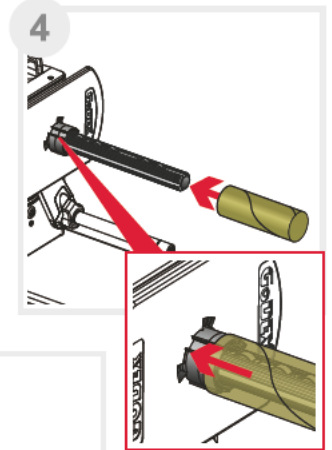
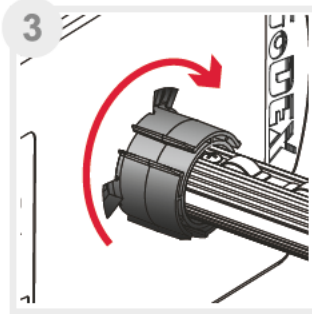
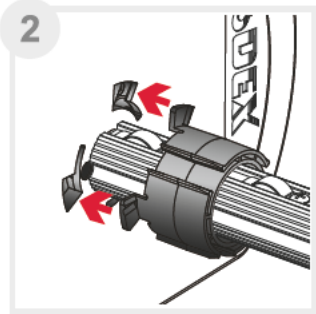
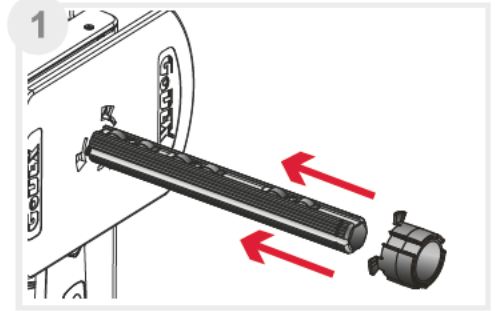
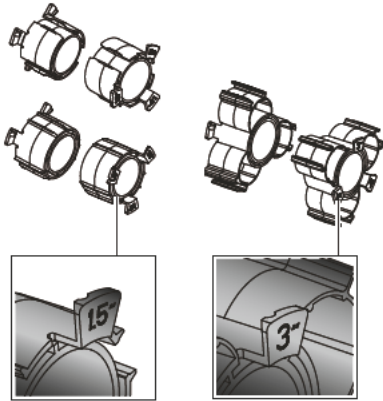

## Use of Label Core Adapters

1'' Empty Label Core  
with Label rewinding shaft.

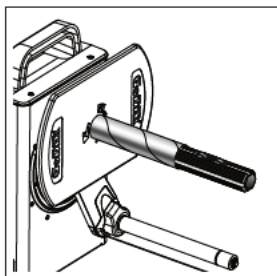

$\Phi 25.2$  to  $\Phi 25.6$  mm  
Tolerable size of inside diameter  
for Label Rewinding Shaft

1.5'' Empty Label Core  
with 1.5'' Core adapter.

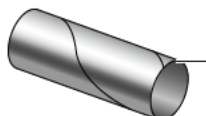
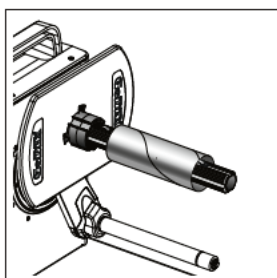

$\Phi 37.4$  to  $\Phi 38$  mm or  $\Phi 40$  to  $\Phi 40.6$  mm  
Tolerable size of inside diameter  
for 1.5'' Core Adapter

3'' Empty Label Core  
with 3'' Core adapter.

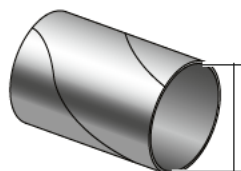
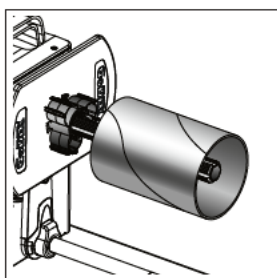

$\Phi 76$  to  $\Phi 76.6$  mm  
Tolerable size of inside diameter  
for 3'' Core Adapter

## Rewinding Modes

### Outside

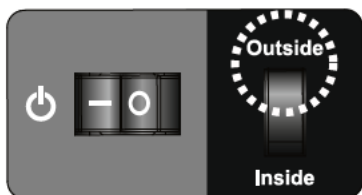

Clockwise

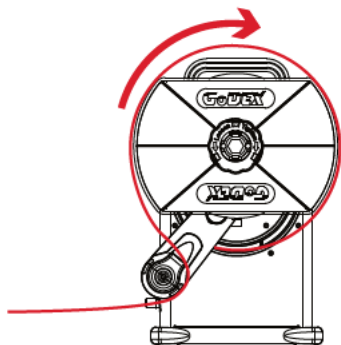

Counterclockwise

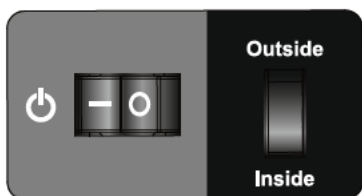
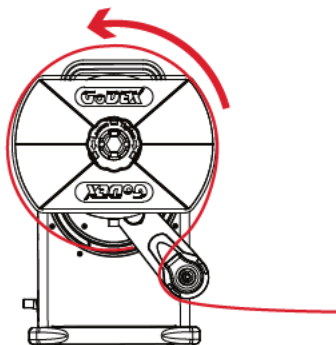

Clockwise

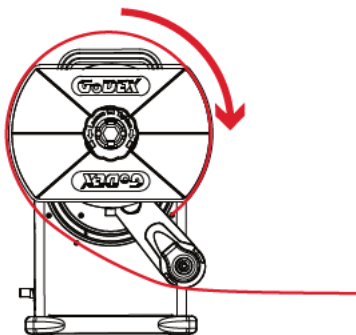

Counterclockwise

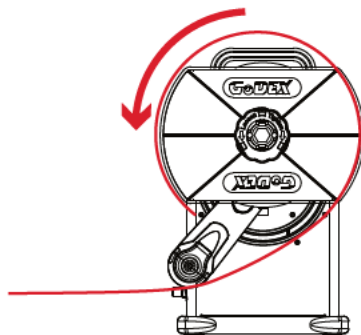

## Motor Fixed Speed Mode

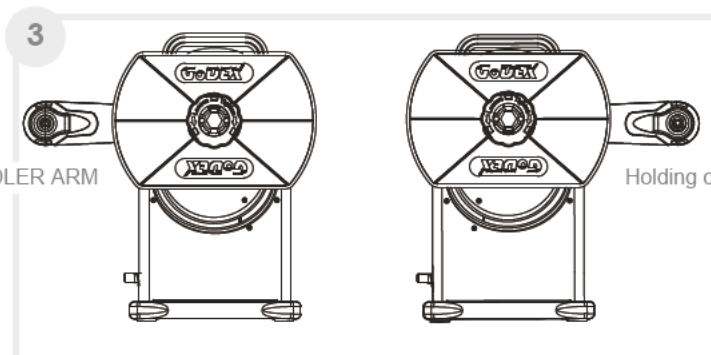
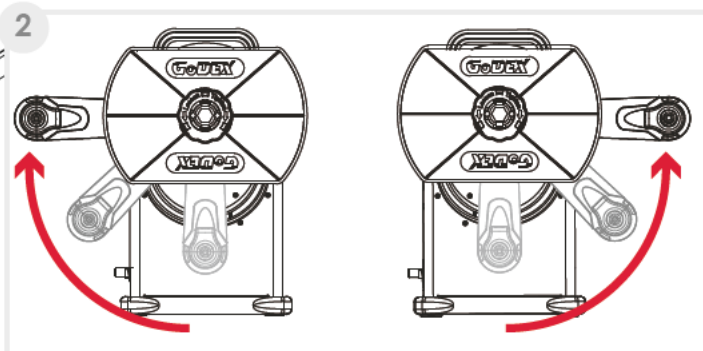
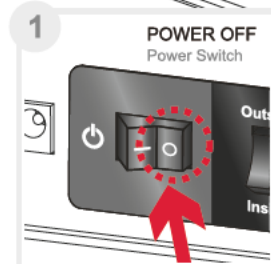
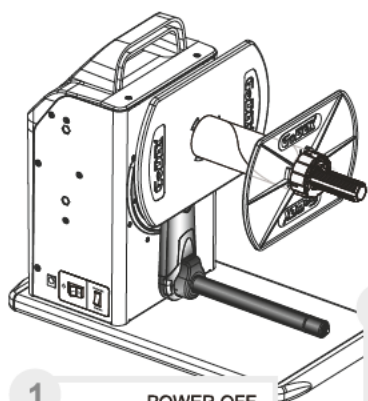

Holding on the IDLER ARM

Holding on the IDLER ARM

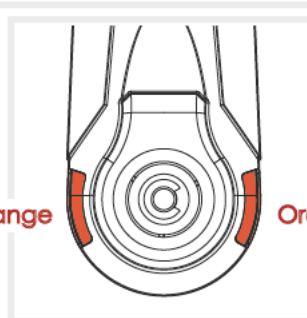
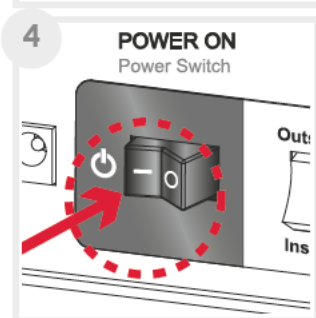

Orange

Orange

5

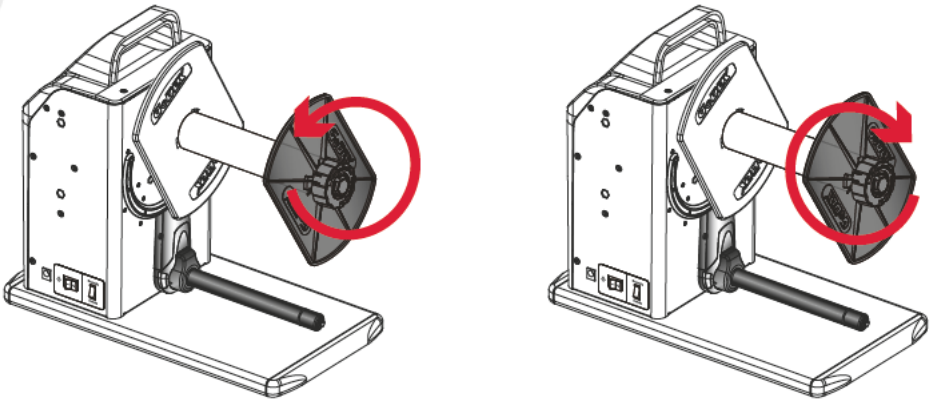

**To Set up:**

1. Make sure the power is switched off.
2. Place the IDLER ARM at its highest point on either side of the rewinder.
3. Turn on the power while holding on the IDLER ARM.

Once the power is on, an orange light should light up and that will bring the rewinder into the "Motor Fixed Speed Mode."

4. Release the IDLER ARM and the rewinder will be rewinding at a fix speed.
5. To stop, switch off the power.

# 4 REWINDER STATUS

## LED Indicator

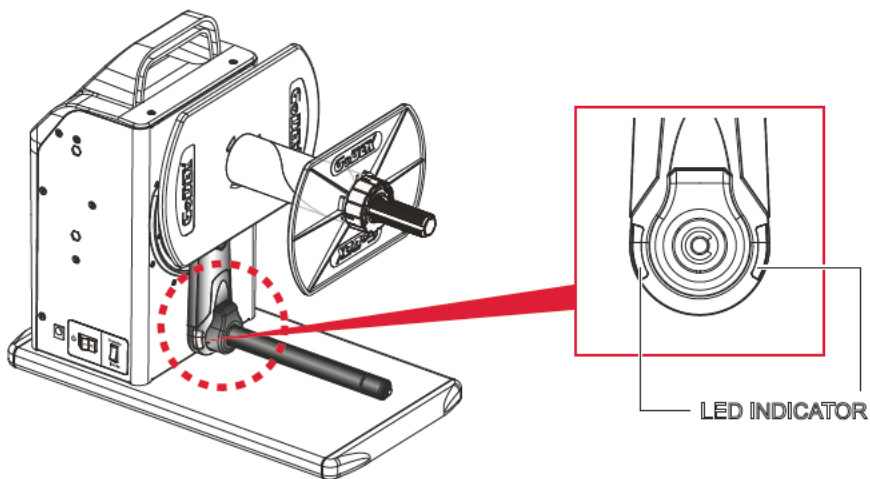

STATUS

LED INDICATOR

Power ON

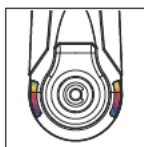

Flash

Outside

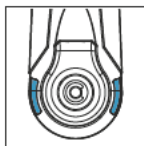

Blue

Inside

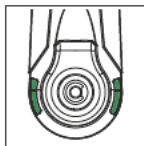

Green

Error / Alert

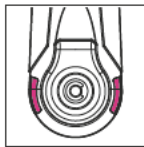

Pink



Power OFF

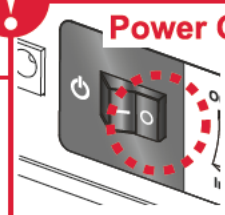

## When The Rewinder Is Full

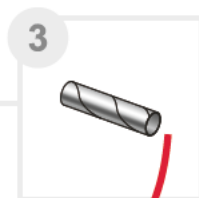
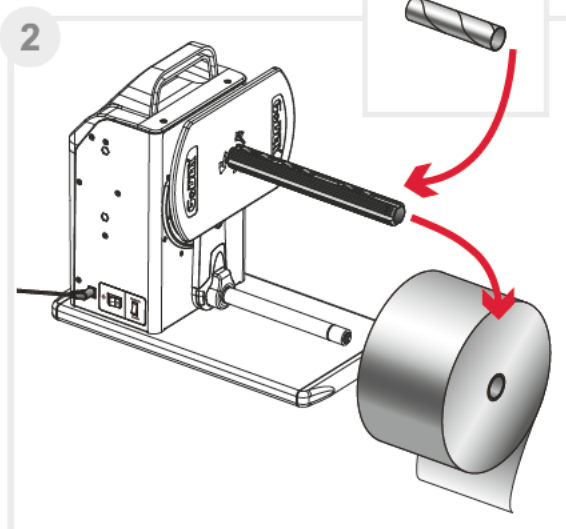
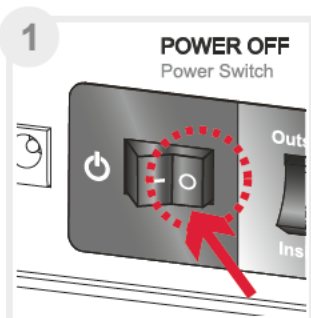
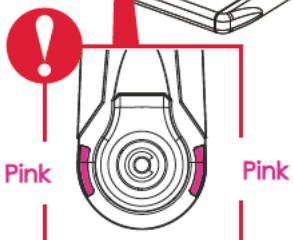
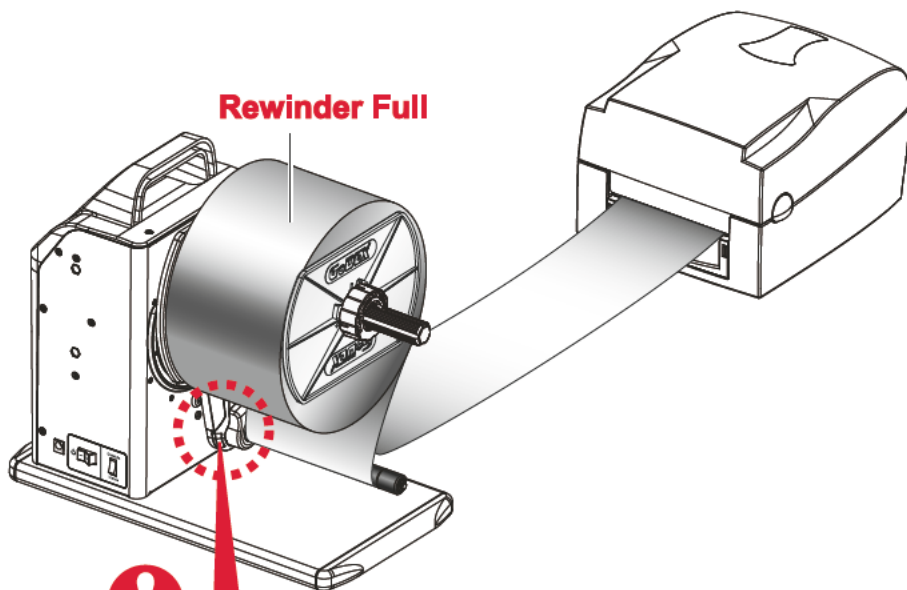



# 5 TROUBLESHOOTING

## Error / Alert

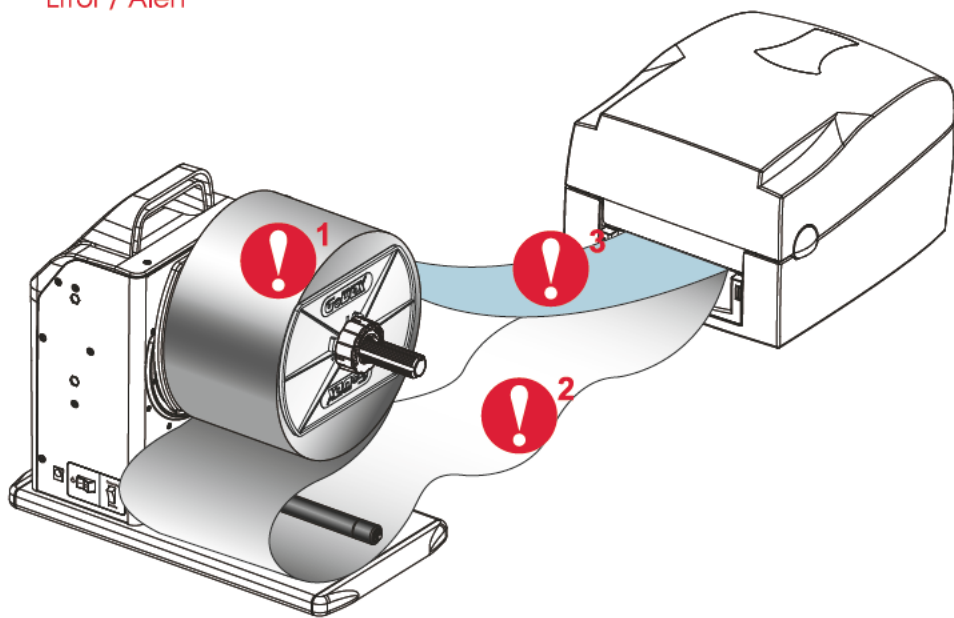

### Error /Alert

### Description



#### Paper Full

refer to "When The Rewinder Is Full" in Section 4



#### Sensing Error

refer to "Sensing Error" in Section 5



#### Idle Load

refer to "Idle Load" in Section 5



## Sensing Error

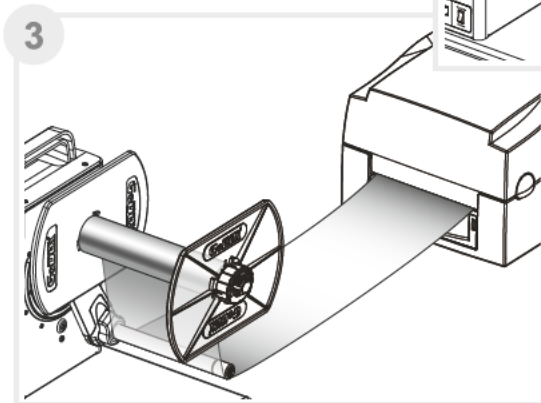
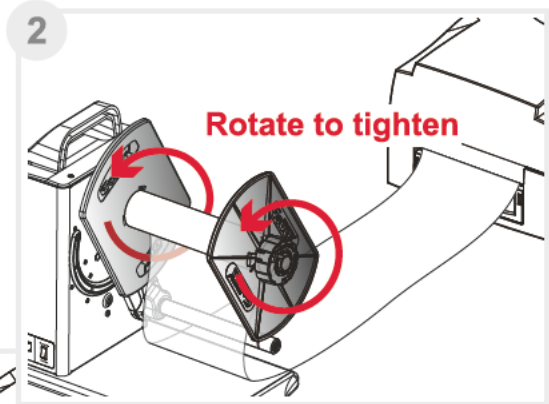
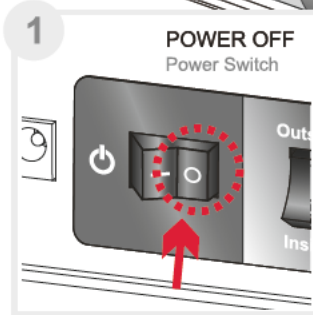
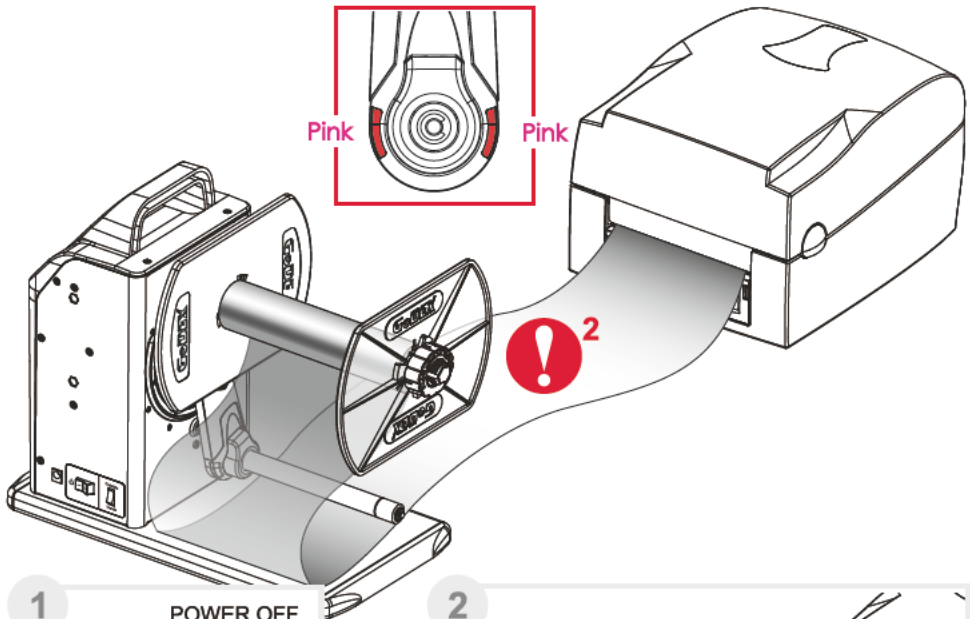

**3** **Idle Load**

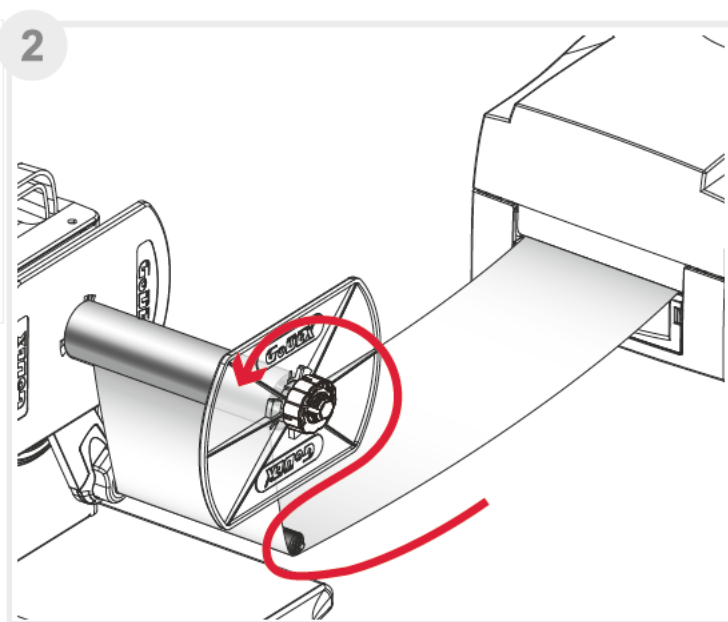
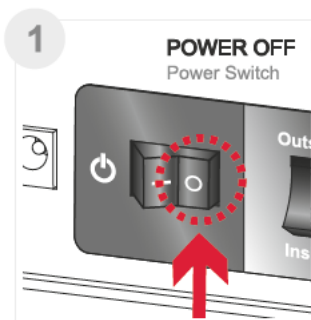
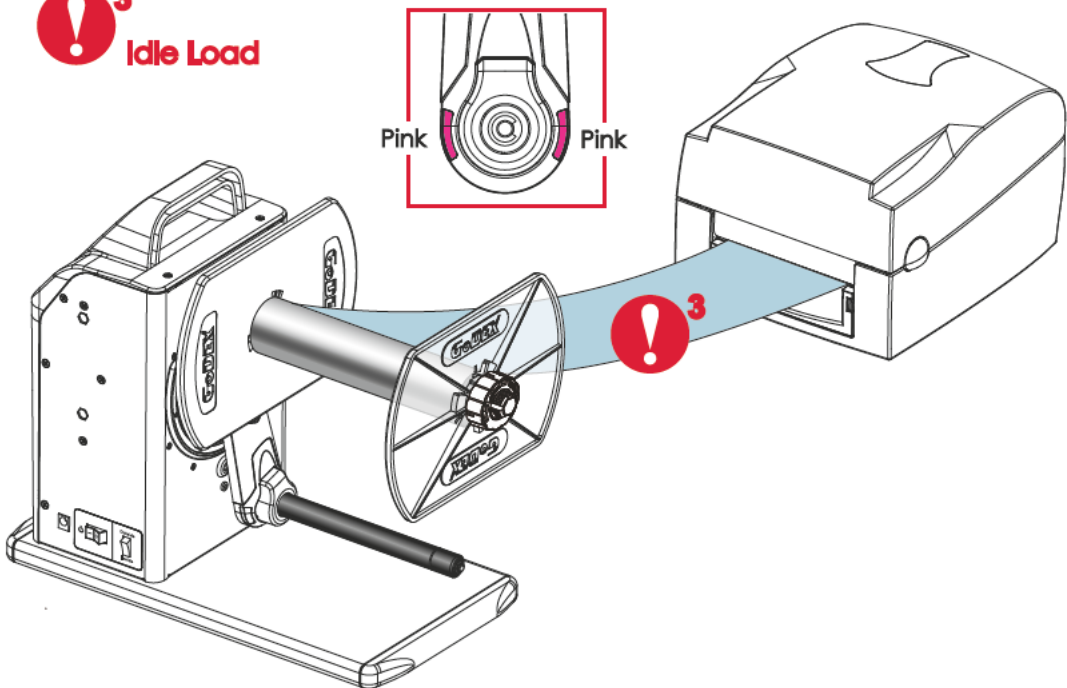

## APPENDIX

## PRODUCT SPECIFICATIONS

Model	T-20 Label Rewinder	
Power width	7" (177.8 mm) Maximum	
Rewind Speed	Auto Mode	12 IPS (305mm/S)
	Fixed Mode	Coreless Adapter (5.4 IPS)
		1" Label Core (6.3 IPS)
Label Roll	6" (152.4mm) Maximum	
Core Diameter	1" (25.2mm - 25.6mm)	
	1.5" (40mm - 40.6mm)	
	3" (76mm - 76.6mm)	
Label Roll Weight	11lb (5Kg)	
Rewinding	Labels Inside or Labels Outside	
Switches	Rewind Control	
Motor	Hybrid Motor	
Power	100 - 240 VAC 24W, 24V Adapter	
Environment	Operating Temperature: 41° F to 104° F (5° C to 40° C)	
	Storage Temperature: -4° F to 122° F (-20° C to 60° C)	
Humidity	10% - 85% non-condensing	
Dimensions(H x W x D)	11.92" (303mm) X 7.09" (180mm) X 15.51" (394mm)	
Agency Approvals	CE, FCC	
Weight	11lb (5Kg)	
Warranty	2 Years	

\* **We do not recommend to rewind die-cut labels. Labels might be torn under certain circumstances.**

\* Specifications are subject to change without notice. All company and/or product names are trademarks and/or registered trademarks of their respective owners.



[www.godexintl.com](http://www.godexintl.com)



Barcodes Made Easy

#### **Godex International (Headquarters)**

13F, No.168, Jian-Kang Road  
Zhonghe Dist, New Taipei City 235 TAIWAN  
Telephone: +886 2 2225 8580  
Fax: +886 2 2225 8480  
Contact us: [infoGT@godexintl.com](mailto:infoGT@godexintl.com)  
Technical support: [techGT@godexintl.com](mailto:techGT@godexintl.com)

#### **Godex Americas**

4023 Camino Ranchero Rd., Ste A  
Camarillo, CA 93012  
Telephone: +1 805 987 5100  
Fax: +1 805 987 5115  
Contact us: [infoGA@godexintl.com](mailto:infoGA@godexintl.com)  
Technical support: [techsupportGA@godexintl.com](mailto:techsupportGA@godexintl.com)

#### **Godex China**

5F, No.68 Jiang Chang 1 Road Shanghai, China  
Telephone: +86 21 5665 1313  
Fax: +86 21 5665 7455  
Contact us: [shanghai@godexintl.com](mailto:shanghai@godexintl.com)  
Technical support: [support@godexintl.com](mailto:support@godexintl.com)

#### **Godex Europe**

Amzhauschen 36 D-42929  
Wermelskirchen, Germany  
Telephone: +49 2193 53396 0  
Fax: +49 2193 53396 69  
Contact us: [infoGE@godexintl.com](mailto:infoGE@godexintl.com)  
Technical support: [technikGE@godexintl.com](mailto:technikGE@godexintl.com)

